



VERSION: V1.00

ISSUED DATE: 2025.05

COPYRIGHT OWNER:

**Note: the company keeps the right to perfect the instruction. If equipment does not agree with the instruction at anywhere, please contact our company in time. We will provide you with corresponding service.**

®

® is registered trademark of

**We reserve all rights to this document, even in the event that a patent is issued and a different commercial proprietary right is registered. Improper use, in particular reproduction and dissemination to third parties, is not permitted.**

**This document has been carefully checked. If the user nevertheless detects any errors, he is asked to notify us as soon as possible.**

**The data contained in this manual is intended solely for the LED description and is not to be deemed to be a statement of guaranteed properties. In the interests of our customers, we constantly seek to ensure that our products are developed to the latest tr c ist**

rt

TT

# CONTENTS



---

**P02**

Overview

**P03**

FEATURES

**P04**

ARCHITECTURE

**P07**

Key Projects

**P08**

Products

---

**P09**

Protection  
IEDS

**P11**

SCU/MU  
CSD-603AWE

**P13**

SCADA  
CSC-2000(V2)

**P16**

Gateway  
CSD-1321

**P18**

Bay Control Unit  
CSI-200E

---

**P21**

Time  
synchronization  
device  
CSC-196

**P23**

Ethernet  
Switch  
CSD-187CN

**P26**

Fault locator  
CSD-193A

**P28**

NDME  
CSGC-SMDS-DG

**P30**

Network  
Analyzer  
CSRA-2000

---



# FEATURES

---

## Cost saving

Simplify hardwiring to significantly reduce Capital Expenditure.

## Space saving

Decrease the substation footprint with a more compact control room design.

## Engineering efficiency

Reduce engineering work and associated costs with simplified secondary circuits.

## Operational efficiency

Enable easier, faster, and remote commissioning to improve operational efficiency.

## Operational safety enhancement

Enhance workforce safety by replacing extensive copper wiring with fiber-optic cables.

## Smart operation capability

Increase situational awareness and asset utilization to enhance overall system reliability.

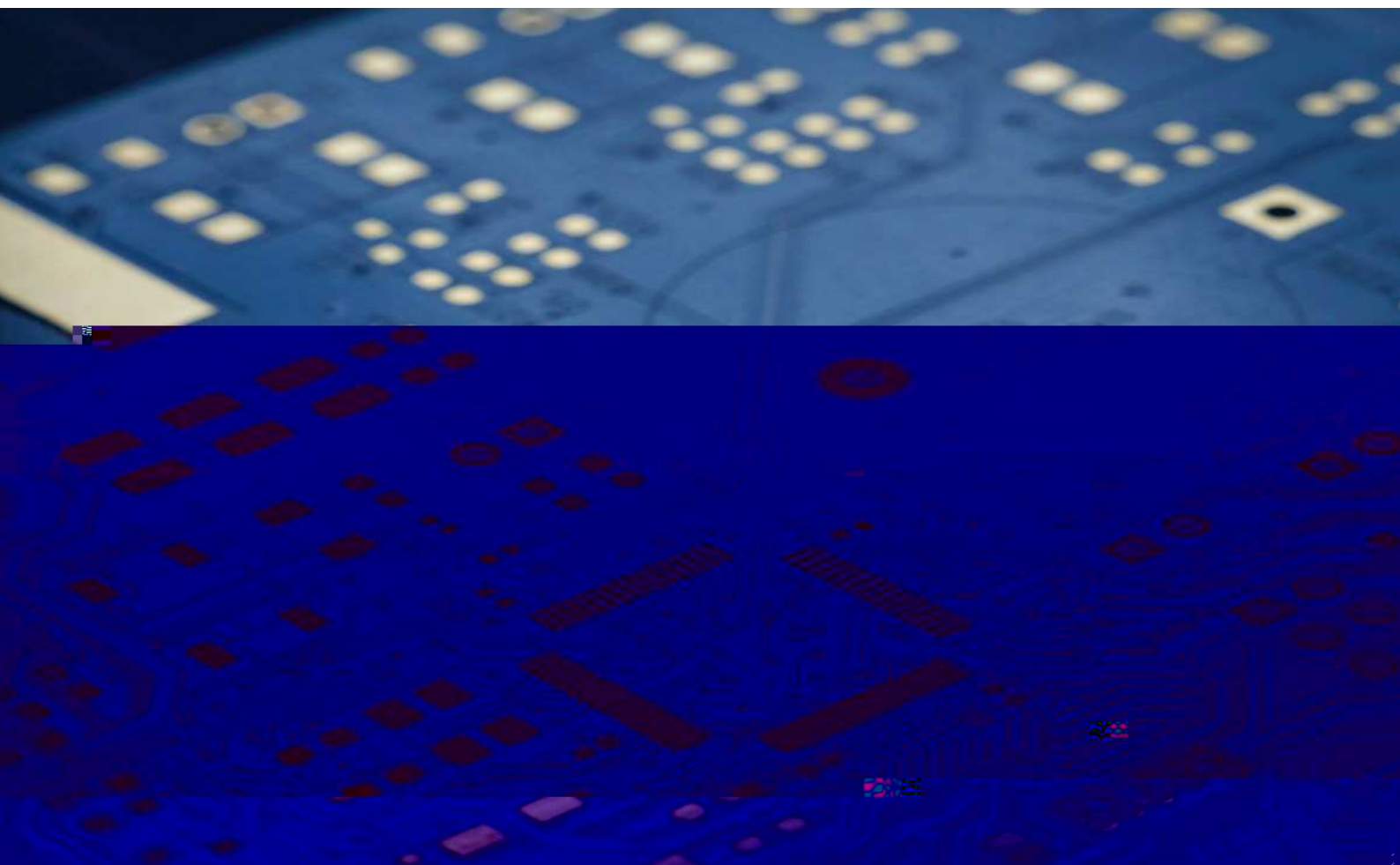

# ARCHITECTURE

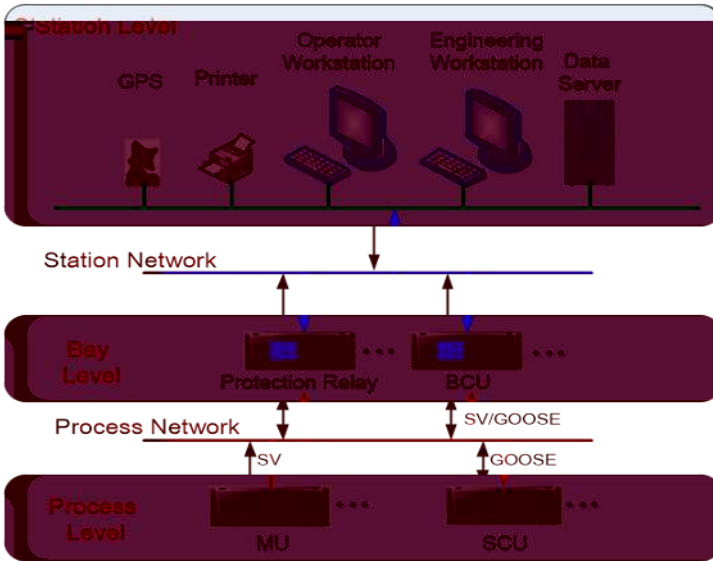

The typical architecture of a SIFANG digital substation is the Three-Level-Two-Networks configuration.

It comprises three levels: station level, bay level, and process level. Additionally, it incorporates two networks: the station network and the process network.

## Station Level

The station level equipment consists of servers, operator workstations, engineer workstations, gateway, and printers, etc.

## Bay Level

The bay level is composed of protection relay, BCU, and NDVE, etc. The network failure at the station network will not affect the function of the bay level equipment.

## Process Level

The Process Level contains the Smart Control Unit (SCU) and Merging Unit (MU). Typically, Merging Units (MU) are used to convert analog signals from the secondary of CTs and VTs to a digital interface. The interface to breakers and disconnect switches is digitized by Switchgear Control Units (SCU). SCUs have a hardwired interface to the breaker trip/close coil to operate the breaker by receiving GOOSE messages from the protection and control IEDs.

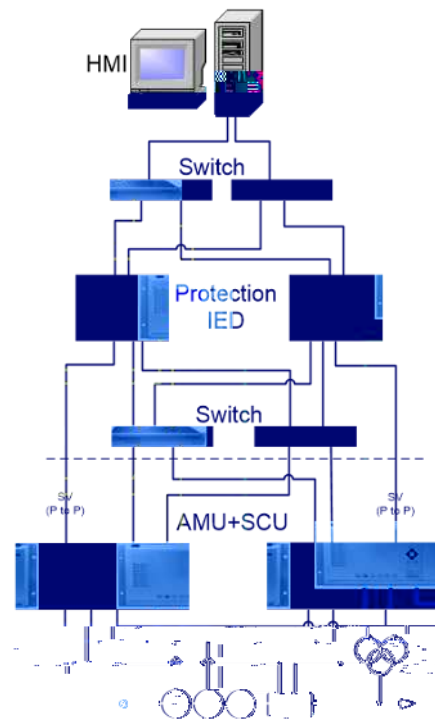
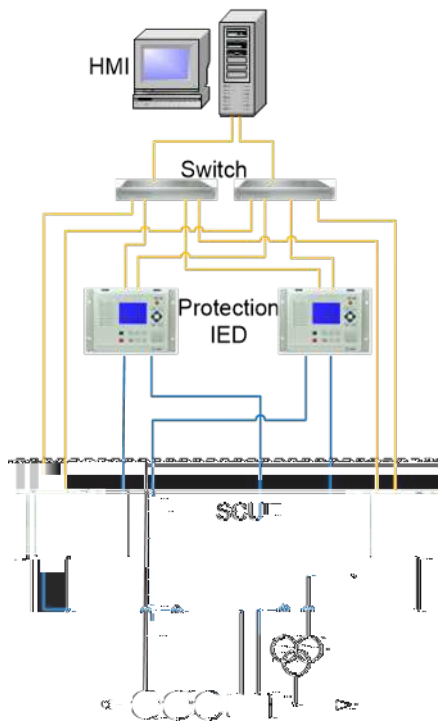
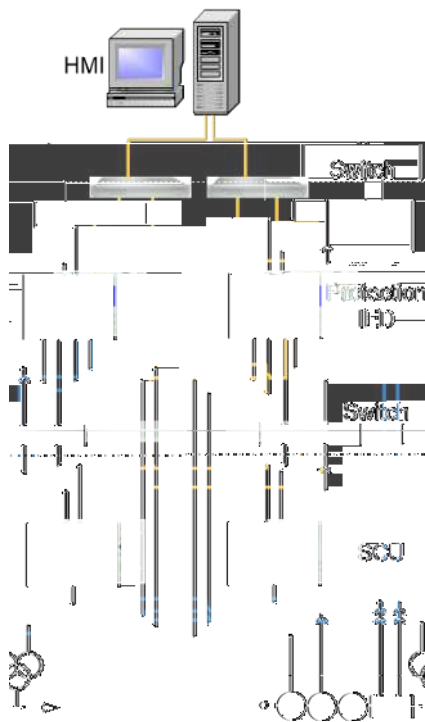

**Typical Architecture 1**  
**Half Digital**

**Conventional Sampling**  
**GOOSE network tripping**

**Station network - MMS/GOOSE, PRP**  
**Process network - GOOSE, PRP**

**Typical Architecture 2**  
**Half Digital**

**Conventional Sampling**  
**GOOSE network tripping**

**Typical Architecture 3**  
**Full Digital**

**SV point to point connection**  
**Goose network tripping**

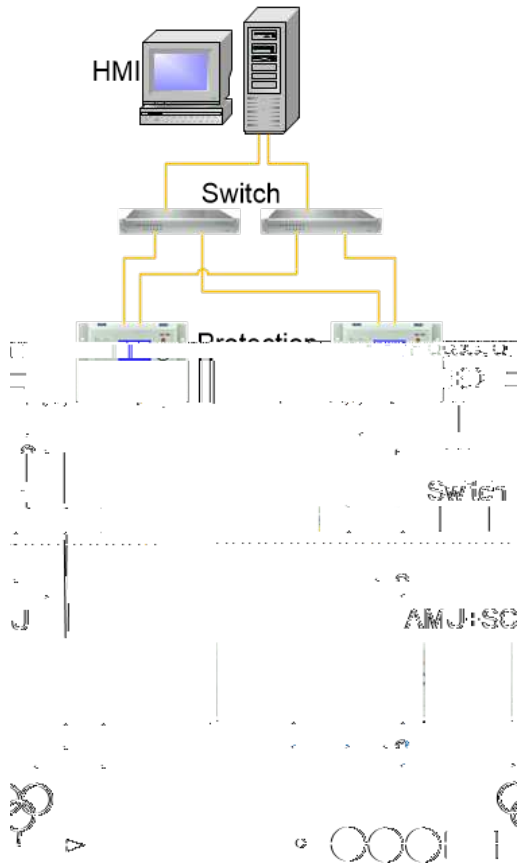

**Typical Architecture 4 Full Digital**

**Full network**

**Station network - IMS/GOOSE, PRP  
Process network - SV/GOOSE, PRP**

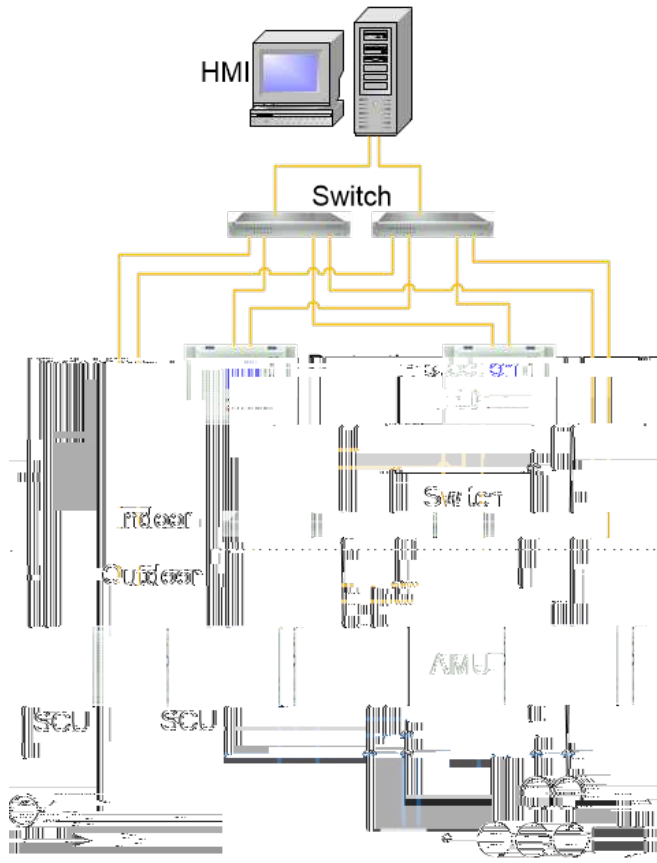

**Typical Architecture 5 Full Digital**

**Full network with dedicated process  
network for SV**

**Station network - IMS/GOOSE, PRP  
Process network - SV, PRP**

---

# KEY PROJECTS

---

## THAILAND PEA DIGITAL SUBSTATION PROJECT

---

- Provincial Electricity Authority (PEA)'s First Digital Substation ➤
- ➤
- 

## NGCP 138KV ISABEL DIGITAL SUBSTATION PROJECT

---

- 
- 
- 
- 
-

# PRODUCTS

## Product Series

Products	Type
Protection Relays*	CSC Series
MU/SCU*	CSD-608
SCADA	CSC-2000(V2)
Gateway	CSD-1321
BOU/RTU*	CSI-200
Time Synchronization Device	CSC-196
Switch	CSD-187
Travelling wave fault locator	CSD-193
Fault Recorder*	CSGC-SMDS-DG
Network Analyzer*	CSRA-2000

\* Smart Device

# PROTECTION CSC SERIES



**SIFANG Protection IEDs cover the entire power system from 1000kV transmission to 6kV distribution. They serve power generation, transmission, distribution, storage and diverse industrial sectors—including petrochemical, iron & steel, metallurgy, rail transportation.**

## Types:

**CSC-108 Line Differential Protection IED**

**CSC-101 Line Distance Protection IED**

**CSC-326 Transformer Protection IED**

**CSC-150 Busbar Protection IED**

**CSC-306 Generator Protection IED**

**CSC-316 Generator Transformer Protection IED**

**CSC-211 Multifunction Protection IED**

**CSC-237 Motor Protection IED**

**CSC-280 Series Multifunction Protection IED**

**CSS-100EE System Stability Control IED**

## Features:

### High-performance hardware platform

- Robust hardware with excellent EMC performance and IP54 protection under -40 to +70 operating temperature.
- Powerful scalable hardware capability, for present and future application.
- Mible CT&VT inputs / SV (Sampling Value) input / output.
- Mible Binary inputs & output relays / GOOSE inputs / outputs.
- Dual (single) CPU, dual A/D acquisition and mutual blocking avoid mal-operation due to internal failure or inference.
- The flexible, scalable and compatible hardware architecture is able to satisfy user's tailor-made hardware scheme.
- Large capacity of recording and log, up to 800 second oscillation record storage.
- Multiple communication ports satisfied all kind of communication demand.

### High reliability hardware and software design concept

- Fully proven and complete protection functions library can be customized into user own function scheme.
- Unique principle of startup element guarantee the correct operation in fault and disturbance.
- Power supply module works correctly even in unstable and intermittent auxiliary power supply system.
- Multiple protection principle to one protected primary equipment of er complete and sensitive protection.
- Complete hardware self-supervision.

### Powerful and friendly software tool

➤ Visual user configuring and logic programming windows make the job convenient and efficient

➤ Capability to precise processing node tracing and fault analysis help engineer catch the fault cause easily and quickly

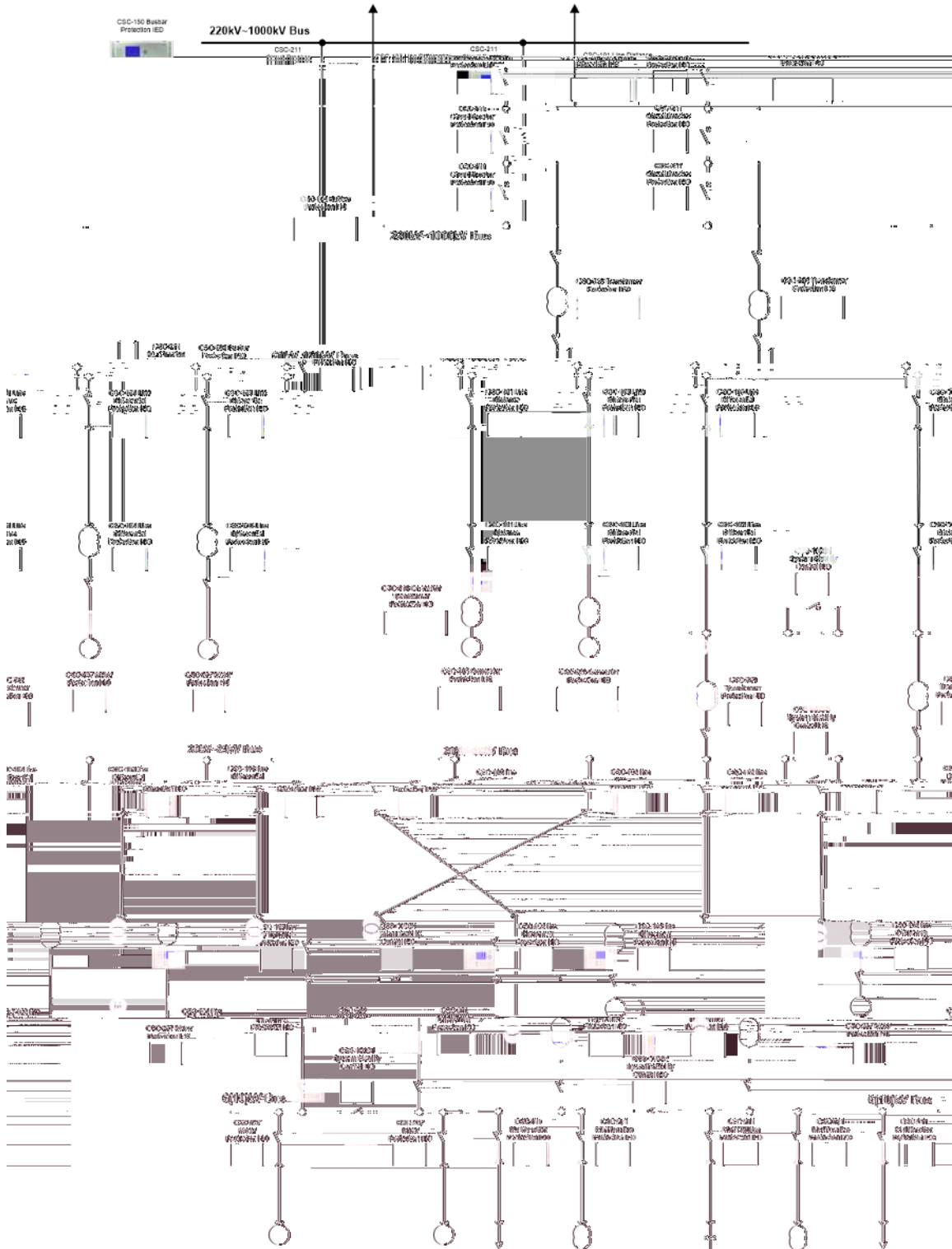

Application Diagram

# SCU/MU CSD-603AWE



The CSD-603AWE serves as both a Smart Control Unit (SCU) and a Merging Unit (MU), providing a physical interface between primary and secondary equipment. It measures currents and voltages from instrument transformers while also exchanging status signals and control commands with primary equipment. All data transmission is performed in a standardized digital format via optical fiber.

## Features:

### ➤ Modular Design

The CSD-603AWE features a modular design, comprising multiple flexible and configurable modules. Key functions—such as analog input, IEC61850-9-2 output, voltage switching and coordination, and digital I/O—can be easily reconfigured through configuration files. This approach enhances both software flexibility and reliability.

### ➤ Time Synchronization with High Precision

CSD-603AWE supports both IRIG-B and IEEE1588 time synchronization. The advanced dedicated time synchronization chip can provide the adjustable time frequency with the time synchronization accuracy excellent than 1 $\mu$ s and the time accuracy excellent 24 $\mu$ s/1hr.

### ➤ Hardware System with High Performance, High Reliability and Massive Resource

CSD-603AWE takes the floating point high performance multi-DSP and industrial grade FPGA with large capacity, integrated transceiver and fast Ethernet technology, to provide the high speed and reliability. It has passed the highest level EMC test for 11 items in the IEC61000 standard for its overall interference immunity.

### ➤ Data Acquisition with High Precision

CSD-603AWE adopts the high resolution 16-bit parallel A/D converter, with dual A/D sampling for each AC channel and it samples 80 points at high speed for each cycle.

## Functions:

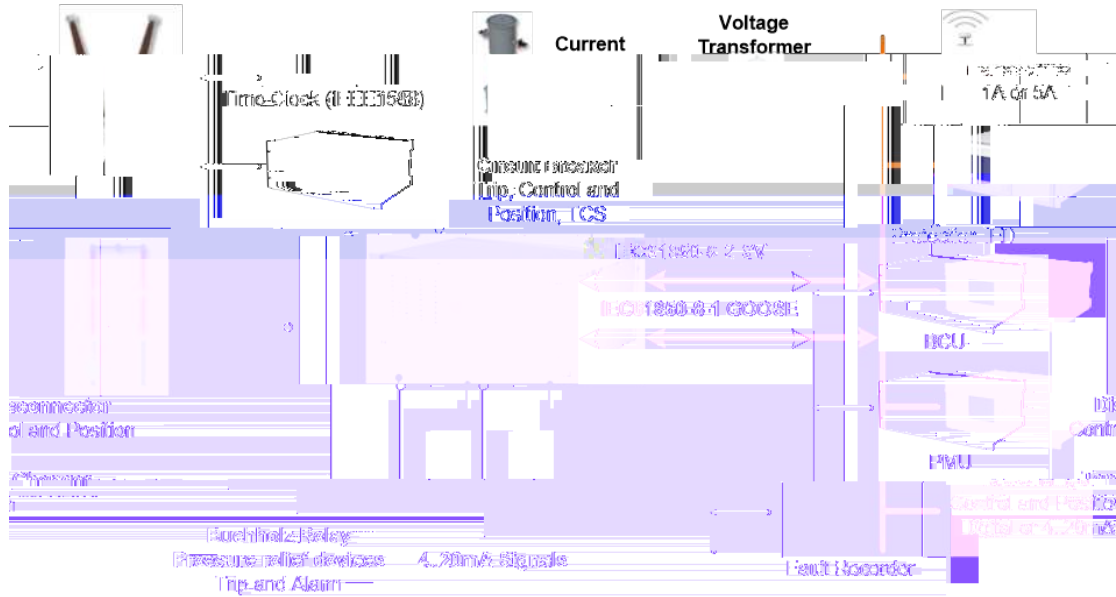

### Technical Specifications

<b>Samplingrate</b>	<b>Trigger Recording</b> 9600 12000/sec@ 60Hz, selectable 4000 9600 10000 12000 12800/sec@ 50Hz, selectable <b>Continuous Recording</b> 1200 2400/sec@ 60Hz, selectable 1000 1200 2400 4000/sec@ 50Hz, selectable
<b>Frequency</b>	50Hz or 60Hz
<b>Accuracy</b>	0.1% on voltage 0.2% on current
<b>AD Conversion Resolution</b>	16bits
<b>RAM Memory capacity</b>	2GB minimum
<b>Mass storage</b>	320G minimum Hard Disk
<b>Time resolution</b>	Records staged to 1ms
<b>Time synchronization</b>	IRIGB and SNTP
<b>Absolute time precision</b>	<50µs with IRIGB
<b>Time keeping accuracy</b>	<500ms with 24 hour time keeping
<b>NDME construction</b>	Microprocessor based/Numerical
<b>Analogy input</b>	64/96/128 selectable Current or Voltage selectable
<b>Binary input</b>	128/192/320/384 selectable
<b>DC acquisition module</b>	(optional) For 4DC inputs with one module Up to 16DC inputs with four modules
<b>GOOSE acquisition module</b>	(optional) For 512GOOSE channels with 4GOOSE modules

# SCADA CSC-2000(V2)

---

**CSC-2000(V2) SCADA system has been operating at 4kV to 1000kV substations and plants for decades. After continuously technology evolving, the system is widely applied from the latest full digital**

**System Architecture:**

### Features:

- Complete hierarchical and distributed architecture makes the system more stable, reliable and efficient.
- System is applicable to mixing platforms with multiple operation systems (Windows/Unix) and multiple hardware systems.
- Redundancy technology is widely used for servers, networks, and gateways to improve system reliability significantly. Different network redundant methods such as PRP, HSR, RSTP, and Dual Lan can be chosen.
- Fully support IEC 61850 and other prevalent communication protocols.
- User-friendly graphic interface allowing operators to perform their tasks easily, efficiently and directly.
- Reliable and flexible switching sequence management can satisfy the requirements for different operating conditions.
- 3 level control modes remote control, SCADA control and local control.
- Modular and scalable architecture with off-the-shelf components.
- Web-Service interfaces and web access are available.
- Complete cyber security measures such as authentication and authorization management, malware protection, antivirus and secure remote access.

### Functions:

- Data Acquisitions
- Graphical monitoring
- Smart Control
- Switching Sequence Management
- Interlock logic
- Event and alarm management
- Report management
- Historian
- Protection management function
- Topology analysis and dynamic coloring function
- VQC subsystem
- Real-time and historical trending
- Authentication and authorization management
- Cyber security



### Technical Specifications

Integrated tolerance of analogue measurement	0.5%
Tolerance of grid frequency measurement	0.01 Hz
Maximal quantity of analogue input signal	50000 extendable
Maximal quantity of binary input	50000 extendable
Maximal quantity of binary output	1000 extendable
SOE	2ms
Operation accuracy rate	100%
Telecommand success rate	99.99%
Telemetry qualification rate	98%
Tele-signalization accuracy rate in fault	99%
System availability rate	99.8%
<b>Workstation CPU average load rate</b>	
In normal condition (in any 30mins)	30%
In power system fault (in 10s)	50%
<b>Automation system network average load rate</b>	
In normal condition (in any 30mins)	30%
In power system fault (in 10s)	50%
<b>Post disturbance review</b>	
Before the fault	5 minutes, extendable
After the fault	10 minutes, extendable
<b>System response time</b>	
Telemetry information response time (from terminal to station level)	3s
Telemetry exceeding limit transmission time	3s
Tele-signalization change response time	2s
Control command output time (from generation to output)	1s

# GATEWAY CSD-1321

CSD-1321 is developed on the SIFANG new generation software platform and hardware platform CSD+, and is mainly used as station level communication management unit in the occasions of substation automation system (SAS), rail transit, new energy, industrial control, etc., with the following typical application scenarios

- Communicate with dispatch center as a Gateway.
- Used as a protocol converter.
- Used as protection management system (PMS) slave unit.
- Used as distributed RTU, together with CSI-200E.



- Communicate with remote control center as data concentrator, transmit the information of the BMS (Building Management System), ESADS (Electronic Security Access Door System), CCTV, transformer online monitoring system etc

## Features:

- 4U height 19 inches width according to IEC 60297-3 Based on SIFANG CSD+ hardware platform with high protection grade: front panel IP54, rear panel IP30 chassis (up, down, left and right) IP30
- The modules can be plug and pull out from the rear.
- Main module adopts embedded 32-bit dual-core 800MHz processor with 2GB DDR3 memory and 128G SSD (or 480G selectable), no cooling fan, low power consumption.
- Main module is based on embedded real time OS
- Pass EMC test with highest class of IEC 60255
- Friendly HMI with key and LCD, tools for configuration and debug
- Distributed architecture, modules are connected through SMBG (smart multi-mode bus group) in the back plate.
- Communication interfaces including Ethernet and serial port can be expanded with modules
- Support IEC 61850 standard as the station level protocol, also support private protocol like CSC-200D
- Communicate with ROC via different type of telecommunication protocols, and protocol converter function can also be integrated
- Communicate with PMS master station via protection protocol, such as TCP/IP based IEC 60870-5-103
- Support time synchronization signal in the mode of SNTP and IRIG-B

**Application:**

➤ **Typical Application 1: Gateway**

CSD-1321 communicates with remote control center (RCC) via IEC 60870-5-101, IEC60870-5-104, DNP3.0 and other telecommunication protocols, and communicates with IEDs via IEC61850 and CSC-2000 protocol. The Ethernet network can be redundant.

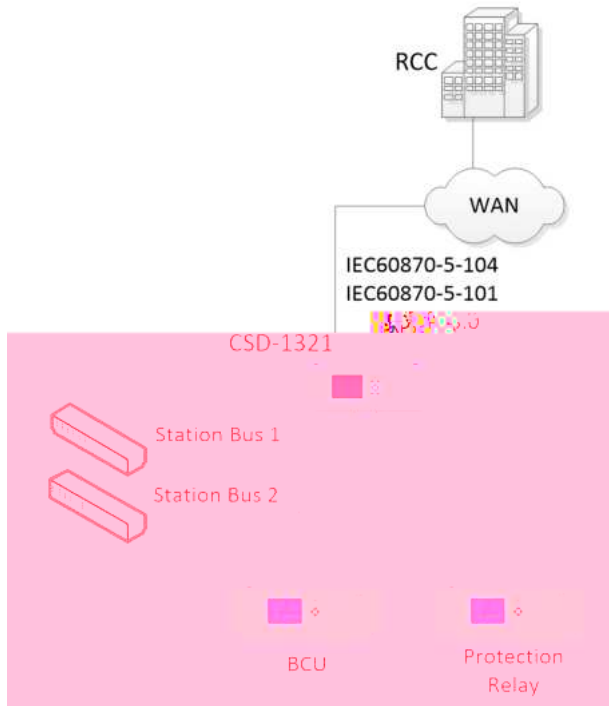

➤ **Typical Application 2 Gateway and Protocol Converter**

CSD-1321 can be configured as gateway and protocol converter at the same time. The diagram below shows the application case.

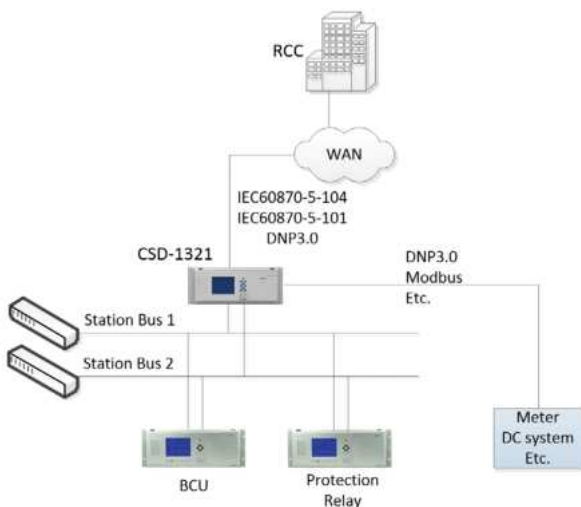

➤ **Typical Application 3 Distributed RTU Solution together with distributed I/O CSI-200E**

CSD-1321 can provide distributed RTU solution together with SIFANG distributed I/O CSI-200E, this solution is nearly same as the gateway application case, CSD-1321 communicates with RCC via telecontrol protocols and communicate with distributed I/O CSI-200E via IEC 61850 protocol.

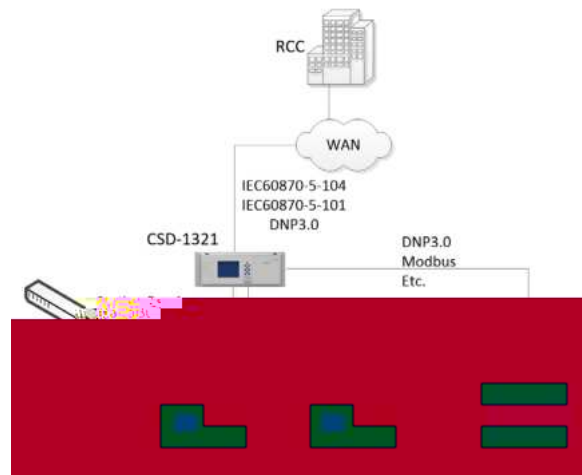

➤ **Typical Application 4 PMS Slave Station**

CSD-1321 can be used as the gateway for PMS slave station which can communicate with PMS master station via protection protocol, such as TOP/IP based IEC 60870-5-103 etc. The DFR can be integrated and the fault wave data can be transferred to PMS master station.

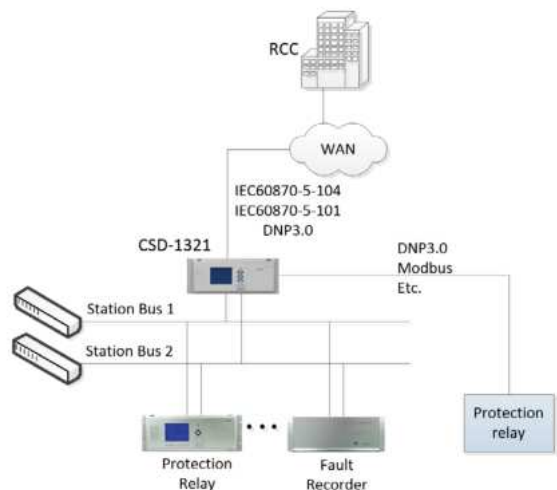

# BAY CONTROL UNIT CSI-200E

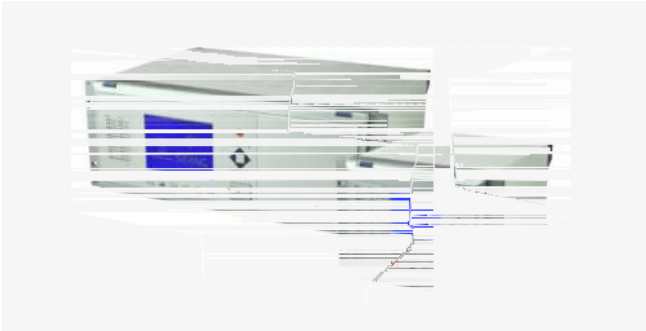

CSI-200E Bay Control Unit (BCU) is a control and automation device in the applications of substations, power plants and other domains

CSI-200E offers typical configurations designed for bay-oriented applications, facilitating engineering use. It also allows flexible module customization based on user requirements

## Features:

### ➤ Flexible configuration

All the modules in CSI-200E are modular designed, connecting through internal bus, and can be plugged-out and installed simply according to the requirements

The software function can also be configured flexibly. User can operate the configuration tools "AESPP" on PC and download the PLC logic diagram to the IED. Bay interlock, synchronization function, on-load tap control and other self-defined logic function can also be achieved.

Mixable CT&VT inputs / SV (Sampling Value) input / output.

Mixable Binary inputs & output relays / GOOSE inputs / outputs

### ➤ Complete event record

Large capacity Flash-ROV is equipped to record fault, alarm, operation and SOE, and data will not lose even when power of , which is convenient for fault analysis

### ➤ Powerful communication function

CSI-200E can provide Ethernet interfaces in both electrical and optical, which support protocol IEC 61850

CSI 200E also supports IEC 62439-3 for parallel redundancy protocol e.g FRP.

### ➤ Local operation function

Local operation button is designed on the front panel of CSI-200E. In case of emergency, authorized user can directly operate the breakers and switches in SLD on the LCD.

## Functions:

### ➤ SLD (Single Line Diagram) display

SLD can be displayed on the LCD and with the button key the object including CB, DS, ES can be operated. SLD can be configured with the AESPP tools

### ➤ Telesignalization

Each EI can be configured separately as status input (double input or single input), alarm input, SOE, transformer tap input (BOD or HEX) and so on.

### ➤ AC measurement

Via AC measurement CSI-200E can calculate the three-phase voltage RMS, three-phase current RMS, 3UQ 3IQ active power, reactive power, power factor, frequency as well as the second to thirteen harmonic

The functions of CT failure, VT failure, zero sequence over limit alarm, phase sequence inverse alarm are also provided.

### ➤ Telecontrol

Tele command from local HMI or remote control center via gateway can be accepted by CSI-200E to operate the CB, DS, ES of the bay. The telecontrol function can be interlock by the local button key or PLC interlock logic.

### ➤ DC measurement

CSI-200E has the function of DC measurement, which is normally used to acquire the signal such as transformer oil temperature, winding temperature, DC bus voltage, and temperature and humidity of intelligent outdoor cabinets.

### ➤ On-load tap control

The tap position signal (BCD code or HEX code) of primary transformer can be collected and submitted. The IED can also respond the telecommand (rise, drop, or stop) from the HMI workstation or ROC to adjust the position of transformer tap.

### ➤ Synchronization function

Synchronization-close can be implemented in different modes including synchronization-check, energizing check or automatic quasi-synchronization.

### ➤ Event record and fault record function

CSI-200E can record fault, alarm, operation and SOE, no less than 2000pos for each type record.

CSI-200E also has the function of synchronous dosing recording, and the recording data can be flexibly configured.

#### Workstation CPU average load rate

Operating temperature

Storage temperature

Relative humidity

#### AC current measurement

Rated current I<sub>ent</sub>

ian e

r

ee e

#### AC voltage measurement

<b>Other measurement</b>	
Rated frequency	50/60Hz, settable
Measuring range of frequency	(0.9~1.1)F
Frequency error	0.008Hz
DC current	4mA~20mA
DC current/voltage accuracy	0.2level
Power measurement accuracy	0.5level
Measurement with timestamp	± 10ms
IRIG-B code/pulse synchronization error	0.5ms
<b>Binary inputs</b>	
Rated voltage $V_{aux}$	110/125/220/250V <sub>ac</sub> , settable or 24/48V <sub>dc</sub> settable
Operating threshold	70% $V_{aux}$ , guarantee operating 55% $V_{aux}$ , guarantee not to operating
Maximum permissible voltage	288V, at $V_{aux}=110/125/220/250V_{ac}$ 62V, at $V_{aux}=24/48V_{dc}$
<b>Output relay</b>	
Maximum contact voltage	250V <sub>ac</sub> /400V <sub>ac</sub>
Current carrying capacity	5A continuous 30A, 200ms on, 15s off
Making capacity	1000V, at $V_{aux}=220V_{ac}$ , L/R=40ms
Breaking capacity	30V, at $V_{aux}=220V_{ac}$ , L/R=40ms
<b>Auxiliary power</b>	
Rated voltage $V_{aux}$	110V to 250V <sub>ac</sub> 24/48V <sub>dc</sub>
Input voltage range	(0.8~1.2) $V_{aux}$
Burden for power supply unit	48W

# TIME SYNCHRONIZATION DEVICE CSC-196

Developed by SIFANG in compliance with Technical Specification for Synchronization System of Power System, the CSC-196 provides high-precision time synchronization signals for power system equipment (e.g., computers, PMUs, protection devices, fault recorders).



## Features:

➤ Compliance & Flexibility

➤ Multi-Signal Redundancy

➤ High Precision

Diverse Outputs

Modular & Robust Design

Smart Compensation & Isolation

Monitoring & Maintenance

## Functions:

Basic time synchronization system

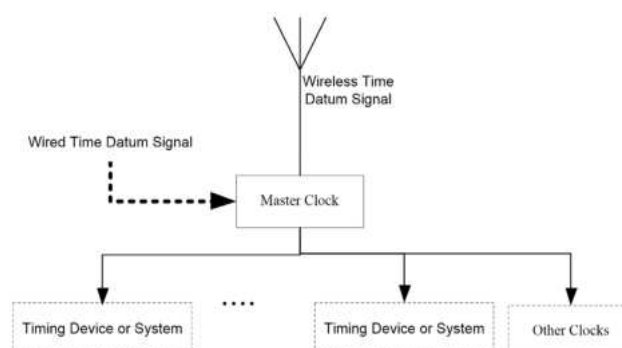

➤ **Master-slave time synchronization system**

The master-slave time synchronization system consists of: a master clock, multiple slave clocks, and a signal transmission medium

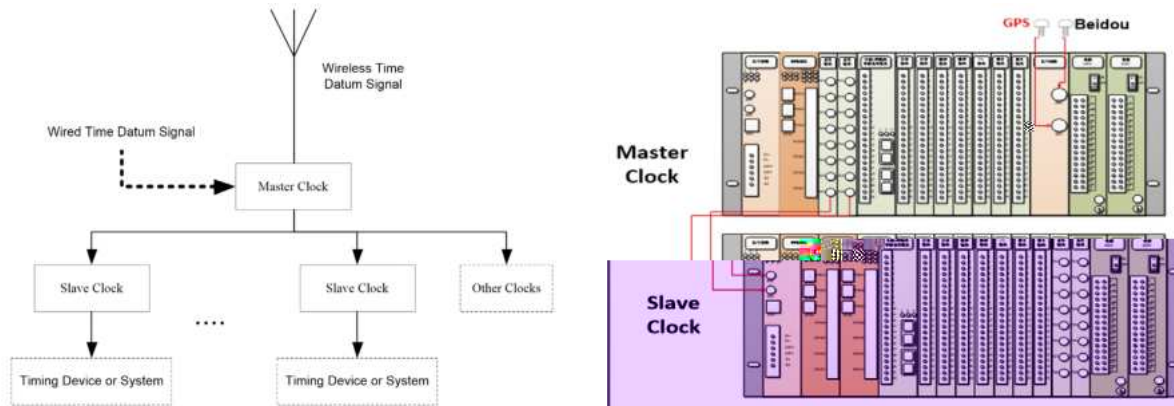

➤ **Hot-standby time synchronization system**

The hot-standby time synchronization system comprises two master clocks (operating in main/backup redundancy), multiple slave clocks, signal transmission infrastructure

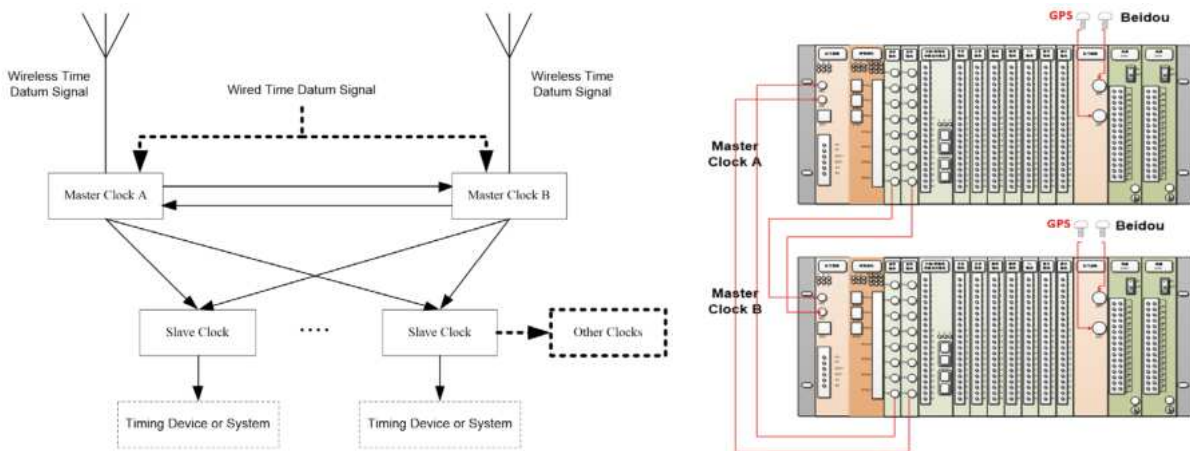

# ETHERNET SWITCH CSD-187CN



The CSD-187CN Series is a high-performance, autonomous, and controllable network switch designed by SIFANG for substation applications. It complies with IEC61850 standards and supports advanced features for power industry scenarios, including automatic configuration, unified management, traffic monitoring, and intelligent alarming.

The CSD-187CN series of substation network switches provide Gigabit Ethernet interfaces, delivering higher data transmission rates to meet the growing demands of equipment communication. The electrical ports default to 100M auto-negotiation but support 1000M operation mode. To enable 1000M, users must configure the port to auto-negotiate at 1000M. The optical ports feature hot-swappable SFP modules, allowing flexible selection of quantity and type based on actual requirements.

## The CSD-187CN series includes the following models

Product Model	Maintenance Port	Service Port			Debugging Port
	RJ45	Electrical Port	100M Optical Port	1000M Optical Port	RJ45
CSD-187CN-Z-E24G4S	/	1-24 <sup>[1]</sup>	/	G1-G4 <sup>[2]</sup>	1
CSD-187CN-G-F16G4S	MMS-A/MMS-B	/	1-16	G1-G4 <sup>[2]</sup>	1
CSD-187CN-G-G16S	MMS-A/MMS-B	/	/	1-16 <sup>[2]</sup>	1

### Note:

[1] Default setting is auto-negotiation mode (100M auto-negotiation), and can support 1000M speed by manually configuring the port speed.

[2] The ports are defaulted to Gigabit optical interfaces and can operate in 100M or Gigabit optical port mode by inserting 100M/1000M SFP optical modules, requiring simultaneous port speed configuration to match different speed SFP modules.

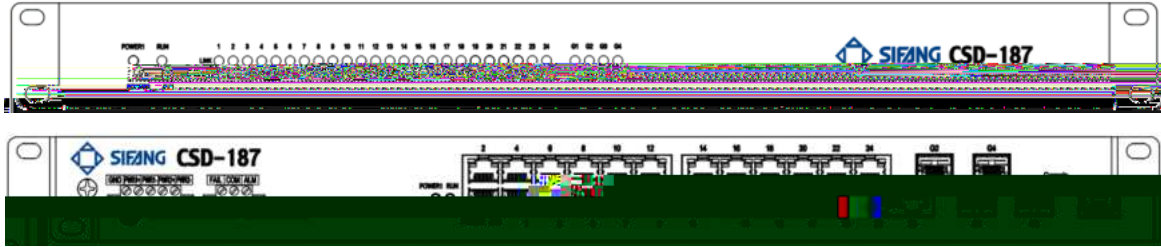

CSD-187ON-Z-E24G4S front view and rear view

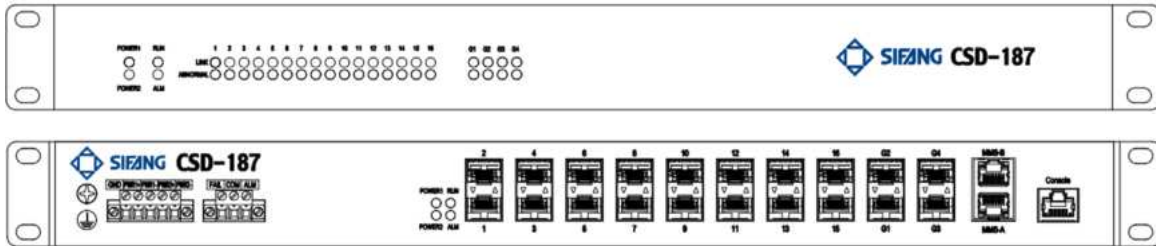

CSD-187ON-GF16G4S front view and rear view

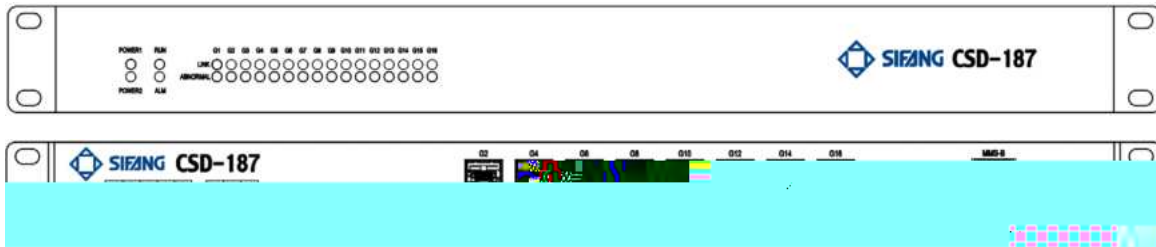

CSD-187ON-G-G16S front view and rear view

## Features:

### ➤ Industrial-Grade Design

Operating temperature: -40° C to +70° C; humidity: 5%-95% (non-condensing).

Redundant dual power supply (AC 220V or DC 110V/220V).

IP40 protection, anti-electromagnetic interference (EMC Level 4 per GB/T 17629).

MTBF: 200,000 hours

### ➤ Network Ports

Electrical Ports: 10/100/1000Mbps auto-negotiation (RJ 45).

Optical Ports: SFP slots (100M/1000M) hot-swappable).

Management Ports: MMS-A/MMS-B (RJ 45, default IP: 192.168.3.254/192.168.4.254).

Console Port: RJ 45 (115200 baud).

## ➤ Advanced Functions

**Auto-Negotiation:** Supports speed/duplex auto-negotiation for electrical ports (default: 100V).

**VLAN:** IEEE 802.1Q (up to 4094 VLANs), port-based VLAN, and VID configuration.

**QoS:** IEEE 802.1p priority (8 queues), strict/weighted fair scheduling.

**Multicast:** Static multicast MAC binding, GMRP dynamic multicast, and storm suppression.

**Security:** MAC/IP whitelisting, port isolation, SNMPv3 encryption, and user role-based access control.

**Reliability:** RSTP ring network protocol (<50ms failover), LLDP for topology discovery.

## ➤ Traffic Control

**Flow Control:** IEEE 802.3x for full-duplex; broadcast/multicast/unknown unicast storm suppression.

**Rate Limiting:** Per-port ingress/egress bandwidth control (4bps granularity).

## ➤ Management

**Web GUI:** HTTPS-based configuration (default IP: 10.10.10.10).

**CLI:** Console/SSH access for advanced settings.

**SNMP:** v1/v2/v3 support for remote monitoring.

**MMS/CMS:** IEC 61850 compliant data services (GOOSE/SV support).

## ➤ Substation-Specific Enhancements

**GOOSE/SV Optimization:** Hardware-based filtering and rate limiting (2Mbps for GOOSE, 15Mbps for SV).

**CSD Offline Configuration:** Preload VLANs/multicast via CID/CSD files (IEC 61850 SCL format).

**Time Synchronization:** SNTP/NTP support ( $\pm 10\text{ms}$  accuracy).

## ➤ Robust Security

**Role-Based Access:** Admin/operator/auditor roles with granular permissions.

**Attack Mitigation:** Anti-DoS, MAC/IP spoofing prevention, and secure firmware updates.

## ➤ Monitoring & Diagnostics

**Real-time port statistics:** errors/drops/throughput.

**SFP health monitoring:** temperature, Tx/Rx power.

**Syslog/SNMP traps for alarms:** power/temperature/voltage.



# FAULT LOCATOR CSD-193A

---

The CSD-193A Transmission Line Fault Locator integrates two fault location principles, travelling wave and impedance-based methods, combining the reliability of impedance measurement with the high precision of travelling wave detection. This dual-method approach ensures highly accurate and dependable fault location.

## Architecture:

## Features:

### ➤ Comprehensive Fault Location Methods

Supports both single-ended and double-ended fault location.

Impedance principle (for reliable distance estimation).

Traveling wave principle (for high-precision detection).

### ➤ Multi-Line Monitoring

### ➤ High-speed AD sampling with

### ➤ Large Capacity Storage & Data Retention

### ➤ Enhanced Reliability & Synchronization

Dual-ended sync startup technology: Ensures fault detection even under weak fault conditions.

Self-diagnostic module check for system health monitoring.

### ➤ Comprehensive Reporting & Logging

Generates operation logs, alarm reports, and fault location records.

Stores up to 2,000 reports with power-loss protection.

### ➤ Flexible Communication Options

4x electrical Ethernet ports (IEC 61850/ TOP103 for substation automation).

3x configurable optical/electrical Ethernet ports (inter-station communication, and fault locator management s G6

### ➤ Precision Time Synchronization

### ➤ The average error of double terminal fault location is less than 500m

---

---

### Functions

Description	ANSI code
<b>Double terminal traveling wave principle fault location</b>	<b>FL2TW</b>
<b>Single terminal traveling wave principle fault location</b>	<b>FL1TW</b>
<b>Double terminal impedance principle fault location</b>	<b>FL2Z</b>
<b>Single terminal impedance principle fault location</b>	<b>FL1Z</b>

# NDME CSGC-SMDS-DG



CSGC-SMDS-DG is a kind of Network Disturbance Monitoring (NDME) and fault-location equipment for 6kV-100kV power grid. It plays an important role to monitor the operation of protection IEDs, and is able to record the whole process of the fault in detail.

CSGC-SMDS-DG can provide mixable CT&VT inputs / SV (Sampling Value) input, and mixable binary inputs / GOOSE inputs

When the fault occurs, NDME can record not only the waveform and RMS value of the three-phase current, voltage and zero sequence current, but also the operating action of protection IEDs, and can provide the detailed report of the fault or disturbance, including but not limited:

- Fault time
- Fault type
- Amplitude and phase of the current and voltage
- Record the time of the fault or disturbance and the action of the relevant protection IEDs and automation IEDs
- The whole operating process of tele-protection function, including transmitting time, stopping time
- The whole operating process of auto reclosing function

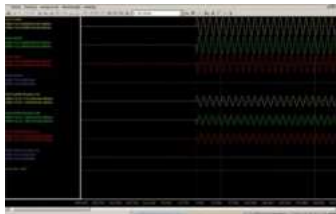

Waveform Analysis

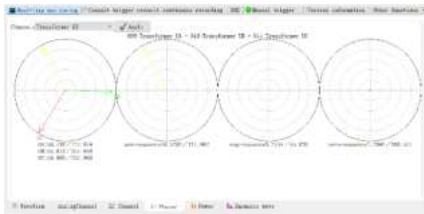

Phasor Analysis

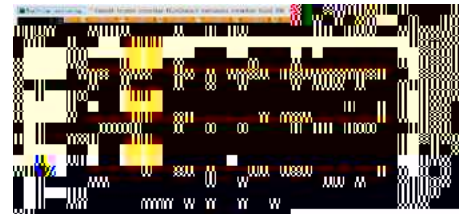

Harmonic Wave

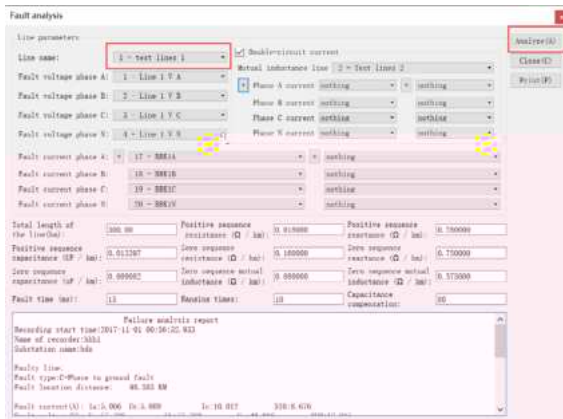

Fault Analysis

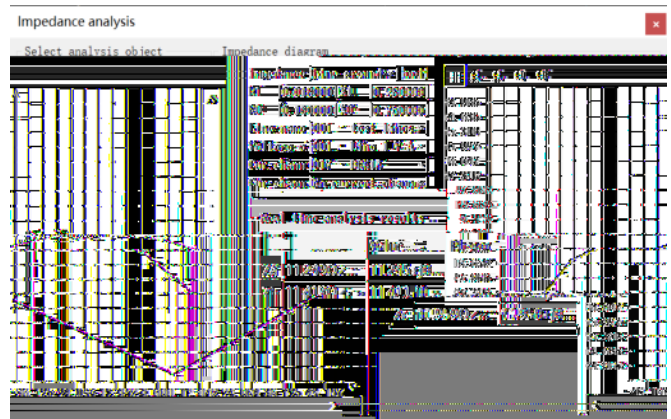

Impedance Analysis

## Technical Specifications

<b>Samplingrate</b>	<b>Trigger Recording</b> 9600, 12000/sec@ 60Hz, selectable 4000, 9600, 10000, 12000, 12800/sec@ 50Hz, selectable <b>Continuous Recording</b> 1200, 2400/sec@ 60Hz, selectable 1000, 1200, 2400, 4000/sec@ 50Hz, selectable
<b>Frequency</b>	50Hz or 60Hz
<b>Accuracy</b>	0.1% on voltage 0.2% on current
<b>A/D Conversion Resolution</b>	16bits
<b>RAM Memory capacity</b>	2GB minimum
<b>Mass storage</b>	320G minimum Hard Disk
<b>Time resolution</b>	Records tagged to 1ns
<b>Time synchronization</b>	IRIG-B and SNTP
<b>Absolute time precision</b>	<50µs with IRIG-B
<b>Timekeeping accuracy</b>	<500ns with 24 hour timekeeping
<b>NDME construction</b>	Microprocessor based/Numerical
<b>Analogy input</b>	64/96/128 selectable Current or Voltage selectable
<b>Binary input</b>	128/192/320/384 selectable
<b>DC acquisition module</b>	(optional) For 4DC inputs with one module Up to 16DC inputs with four modules
<b>GOOSE acquisition module</b>	(optional) For 512GOOSE channels with 4GOOSE modules

# NETWORK ANALYZER CSRA-2000

The Network Analyzer CSRA-2000 is used to online monitor and record the communication messages of all kinds of protocols in substation communication network, including SV, GOOSE, MMS, IEC104



## Architecture

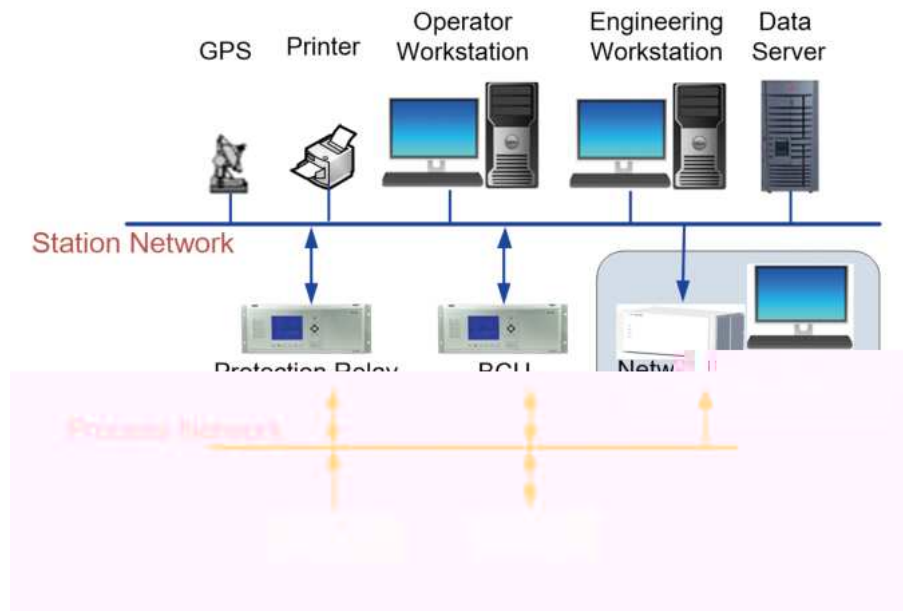

### Management Unit (CSRA-2000-NMU) Functions:

- **Data Aggregation and Analysis**  
Collects analysis results from all collection units, performs station-wide communication data statistics and analysis, and uploads results  
Supports retrieval and storage management of recorded files

- **Real-Time Monitoring and Alarms**  
Displays the communication link status (normal/abnormal/static configuration) of all station devices, supporting real-time monitoring of MMS, GOOSE, and SV protocols  
Provides alarm functions for anomalies such as device failures, communication interruptions, and model inconsistencies

### ➤ Query and Statistics

Supports querying events, statuses, point information, and statistical values by time, device and protocol type, etc

Statistical dimensions include packet count, byte count, communication interruption frequency, protocol errors, etc

### ➤ Packet Analysis Tools

Parses IEC 61850, GOOSE, SV, and other protocol packets, supporting traffic analysis, session statistics, IP/MAC mapping table queries, etc

### ➤ Configuration Management

Imports SCD files and configures parameters such as the number of collection units, IP addresses, and storage paths

Manages user permissions and audits operation logs

## Collection Unit (CSRA-2000-NCU) Functions

### ➤ Packet Capture and Recording

Uses FPGA hardware for real-time packet capture with timestamping (resolution 1μs).

Supports long-term continuous recording: SV/GOOSE/MMS packets 7 days (average traffic 200Mbps). Storage medium 4TB hard drive, supports categorized storage.

### ➤ Online Protocol Parsing

Parses packets at each layer (network layer, protocol layer, application data layer) during communication.

Identifies network anomalies (e.g., traffic spikes, frame loss), protocol errors (e.g., GOOSE bit inconsistency), and data anomalies.

### ➤ Performance Specifications

Single-interface capacity: 100Mbps (electrical/optical ports).

Long-term stable operation capability: 200Mbps (non-SV packets 10%).

Supports IEC 61850 time synchronization with accuracy <1μs.

### ➤ Self-Test and Alarms

Features self-reset functionality and monitors hardware status (e.g., CPU, memory, temperature).

Indicates faults/alarms via LEDs and relay outputs (e.g., power loss, storage medium failure).

## Technical Specifications

### ➤ Monitoring interface and access capability

1 Management Unit:

610/100/1000M adaptive Ethernet port

Report access capability of a single interface: 100Mbps

2 Collection unit:

8LC module collection ports, can be configured as optical or electrical ports, and the last 2 support gigabit optical ports

The maximum reported access capacity of the device during long-term stable operation is 250Mbps (25MU).

### ➤ Timing synchronization accuracy

Collection unit: Electric IEC 61850, with a timing accuracy of less than 1μs and a 1-hour timing accuracy of less than 1ms;

Management unit: SNTP or electrical IEC 61850, with timing accuracy less than ± 1s

### ➤ Data record capability

Capture time resolution <1μs

Continuous recording and storage of SV reports for 7 days

Continuous recording and storage of GOOSE reports for 7 days

Continuous recording and storage of MMS reports for 7 days

Storage of 'status' and 'event' categories for 7 days, 'Statistics' storage for 3 days

Reports file recording method: classified storage

Storage hard disk capacity: 4TB

Stock Code

501126

BEIJING